



Bord Agrément na hÉireann
Irish Agrément Board

CERTIFICATE NO.05/0216

Kilkenny Pre-Cast Concrete Ltd.,

Hebron Road, Kilkenny

Tel +353 (0) 56 7721013

Fax +353 (0) 56 776 5558

email : kilkconc@iol.ie

website: www.kilkennyprecast.ie

KPC Biofilter Wastewater Treatment System for Single Dwellings

Systèmes de Traitement des Eaux Résiduares
Abwasser Aufbereitung

The Irish **Agrément Board** is designated by Government to issue European Technical Approvals.

Irish Agrément Board Certificates establish proof that the certified products are 'proper materials' suitable for their intended use under Irish site conditions, and in accordance with the **Building Regulations 1997 to 2002**.

The Irish Agrément Board operates in association with the **National Standards Authority of Ireland (NSAI)** as the National Member of UEAtc.

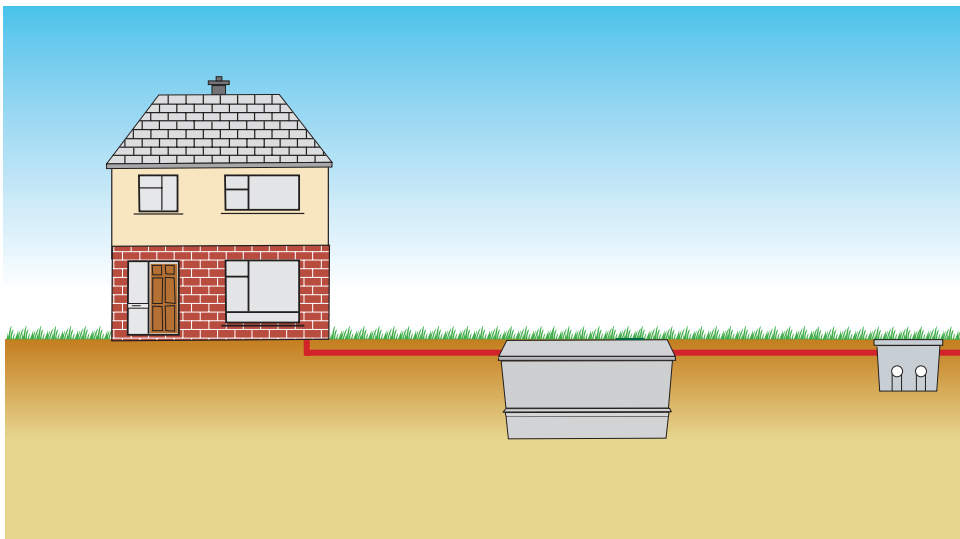

PRODUCT DESCRIPTION:

This Certificate relates to the KPC Biofilter Wastewater Treatment System for Single Dwellings. The combined aerobic/anaerobic system utilises the Biological Aerated Filter (BAF) process, to treat domestic wastewater, from dwellings with a population equivalent of up to eight persons.

The unit is comprised of a five chamber concrete tank.

The tank treatment capacity is 5350 litres. In the event of failure, the retention time of the primary chamber is in excess of 48 hours and the de-sludging interval is at least one year.

The life of the unit, when installed and operated in accordance with the Certificate holder's instructions, should be in excess of 50 years. However, mechanical components, subject to normal wear and tear, will require replacement within this time.

USE:

The product is for use in wastewater treatment systems designed to meet the requirements as specified in BS 6297: 1983 *Code of practice for design and installation of small sewage treatment works and cesspools*, and the EPA *Wastewater treatment manual – Treatment Systems for Single Houses 2000*, for the collection and treatment of domestic wastewater, including the separation and partial digestion of suspended matter, prior to discharge of the treated effluent.

MANUFACTURE AND MARKETING

The product is manufactured and marketed by:

Kilkenny Pre-Cast Concrete Ltd, Hebron Road, Kilkenny.

Tel +353 (0) 56 7721013 Fax +353 (0) 56 776 5558

email : kilkconc@iol.ie, website: www.kilkennyprecast.ie

REVISIONS

There have been no revisions to this certificate to date.

Readers are advised to check that this Certificate has not been withdrawn or superseded by a later issue by contacting the Irish Agrément Board, NSAI, Glasnevin, Dublin 9 or online at www.n sai.ie/iab/04/050216

1.1 ASSESSMENT

In the opinion of the Irish Agrément Board (IAB), the KPC Biofilter Wastewater Treatment System is satisfactory for the purpose defined above, and can meet the requirements of the Building Regulations 1997 to 2002, as indicated in Section 1.2 of this Certificate.

1.2 BUILDING REGULATIONS 1997 TO 2002

REQUIREMENT

PART D – MATERIALS AND WORKMANSHIP

D1 - The KPC Biofilter Wastewater Treatment System, used in accordance with this Irish Agrément Board Certificate, meets the requirements for materials and workmanship.

D3 - The KPC Biofilter Wastewater Treatment System, as certified in this Irish Agrément Board Certificate, is manufactured from proper materials and is fit for its intended use. See Part 4 of this Certificate.

PART H - DRAINAGE AND WASTE DISPOSAL

H1 Drainage systems

The KPC Biofilter Wastewater Treatment System, as certified in this Irish Agrément Board Certificate, is manufactured from proper materials and is fit for its intended use. See Part 4 of this Certificate.

H2 Septic tanks

The KPC Biofilter Wastewater Treatment System has been designed for use in wastewater treatment systems, for the collection and treatment of domestic wastewater, when installed in accordance with the recommendations of BS 6297:1983 and the EPA *Wastewater treatment manual – Treatment Systems for Single Houses 2000*.

The quality of effluent from the KPC Biofilter Wastewater Treatment System exceeds that of the effluent from a septic tank and can meet the Building Regulation requirements.

Information on the design capacity, ventilation, safety and location requirements is given in this Irish Agrément Certificate. See Part 3 and 4 of this certificate.

2.1 PRODUCT DESCRIPTION

2.1.1 System Details

The KPC Biofilter Wastewater Treatment System utilises the Biological Aerated Filter (BAF) process, to treat domestic wastewater, from dwellings with a population equivalent of up to eight persons.

The unit is comprised of a rectangular fibre/mesh Grade 40 N reinforced concrete five-chamber tank and lid. The two access covers are also manufactured from fibre reinforced concrete. The air blower housing is manufactured from polyethylene.

Within the aeration chamber, an electrically powered air diffuser, which is powered by an electrical air blower, supplies oxygen to the biological media in the aeration zone. The air blower is located in a polypropylene chamber sitting within the lid of the tank. The air blower operates continuously off a normal domestic power supply and is connected to the dwelling served by a residual current circuit breaker. The control unit/alarm is generally located within the dwelling house.

Inlet and outlet pipe connections are provided.

The unit is vented through an opening cast into the tank lid.

The unit is accessed via two pedestrian concrete access covers, designed to be flush with ground level.

Discharge from the tank is by gravity.

Provision can be made for pumped discharge, by incorporating an additional pump if required. Pumped systems shall be designed by a competent person. Adequate provision should be made for storage in the event of pump failure. This is outside the scope of this certificate.

2.1.2 Treatment

Treatment is carried out in three phases, as follows:

Zone 1

Domestic wastewater enters the primary chamber through the inlet pipe. Here, heavy solids settle onto the base of the compartment, where they remain until desludging. Lighter debris and grease rise to the surface to form a crust. The effluent passes, by displacement, into the aeration chamber.

Zone 2

Supernatant liquor passes through the aeration chamber, where it is broken down by microorganisms which grow on the surface of the biofilter media. The air compressor supplies air to the diffuser in the base of the chamber, thus ensuring that the liquor is continuously aerated and mixed.

Zone 3

The treated liquor passes through the settlement and polishing chambers before entering the final clarifier. It is then discharged by gravity to the percolation area. Settled sludge is continuously returned to the aeration chamber by venturi action.

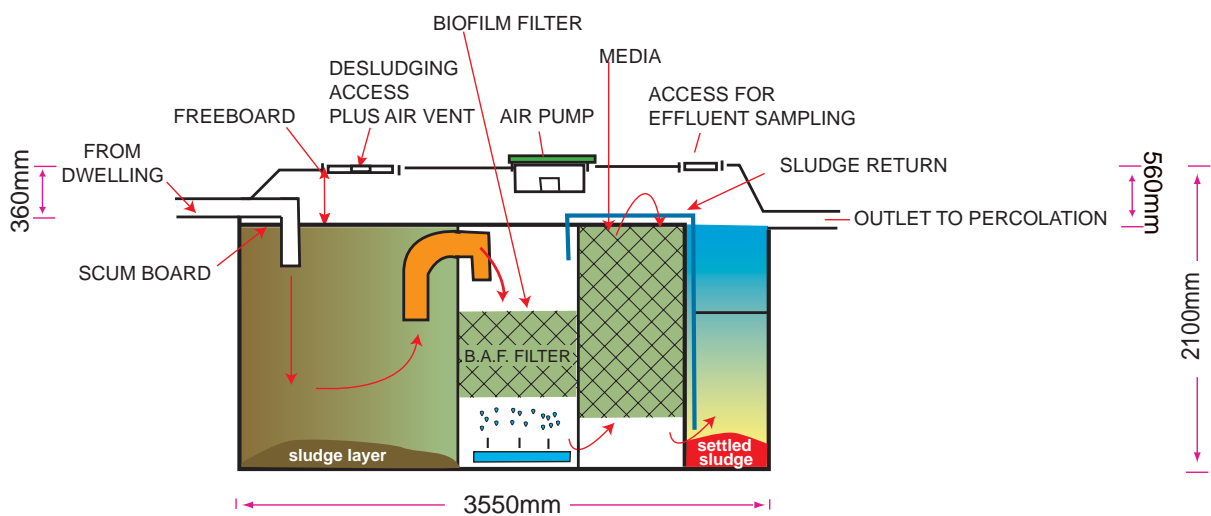

Figure 1: Section Through Tank

Table 1.: KPC Biofilter Wastewater Treatment System – basic information

Treatment capacity	5350 litres
Primary chamber treatment capacity	2600 litres
Aeration chamber treatment capacity	1540 litres
Aeration settling chamber	450 litres
Polishing chamber	225 litres
Final clarification chamber	540 litres
Design population	8 PE
Overall width	1300 mm
Overall length	3550 mm
Total Height (including cover)	2100 mm
Weight	
Tank base (empty)	4500 Kg
Tank lid	1300 Kg
Design flow rate	1440 litres/day
BOD load	0.48 Kg/day
Inlet invert to base	1800 mm
Outlet invert to base	1600 mm
Ground level to inlet invert level	360 mm
Ground level to outlet invert level	560 mm
Compressor motor rating	80 watt
De-sludge period	1 year minimum
Retention time (based on design flow)	89 hours

2.2 MANUFACTURE

2.2.1 General

The tank and lid are cast from fibre/mesh G40N concrete. The wall thickness varies from 125 mm mm, at the base, to 75 mm at the top. The tank floor is 100 mm thick. Minimum cover to all reinforcement is 30 mm.

All plumbing joints are formed using push fit connections and are solvent sealed. The internal pipe work and the air diffuser are fitted prior to final testing. The air compressor chamber is fixed to the tank cover. The inlet and outlet pipes and connections are fitted and labels applied.

2.2.2 Product range

The system is designed to collect domestic wastewater from dwellings having a population equivalent of up to eight persons. System details are shown in Table 1.

Ancillary items

- 110 mm uPVC drainage pipes and sockets to BS 4660: 2000 *Thermoplastics ancillary fittings of nominal sizes 110 and 160 for below ground gravity drainage and sewerage*
- ABS internal pipe work
- Polyester braided flexible PVC hose piping
- Stainless steel joint fixing clips
- Quartz air diffuser assembly
- Air blower (80 watt)
- Corrugated polypropylene biomedica sheets
- Electrical control panel, high level float switch and alarm
- electrical cable glands
- joint sealant (styrene butidane rubber [SBR] mortar)

All components in contact with effluent are made of stainless steel, uPVC or polyethylene.

Quality control

The Certificate holder operates a quality management system and continuous quality control is exercised during manufacture. Quality checks include qc checks on incoming raw materials and ancillaries, concrete cube and slump tests, dimensional checks, equipment calibration, load tests, operational testing of air blower, diffuser and sludge return system, visual inspection and water tightness testing.

2.3 DELIVERY, STORAGE AND MARKING

The unit is delivered to site, by Kilkenny Pre-cast Concrete Ltd, for assembly. The tank is transported and lifted using a specially designed truck mounted crane. The tanks are cast with a projecting rib at each end for lifting with certified triangulated lifting tackle, in accordance with the Certificate holder's instructions. Off loading shall be carefully supervised and lifting equipment shall be selected taking into account the unit weight, dimensions and the distance of lift required (see Table 1). All lifting equipment and procedures shall comply with the requirements of the Safety, Health and Welfare at Work Act 1989. The Certificate holder's instructions shall be followed to avoid damage to the tank during off-loading and installation.

Each tank base and lid unit bears a unique serial number, for traceability purposes. The Certificate holder's details, model type and population equivalent capacity, are also listed on the base, lid and air blower chamber cover, so that details remain visible once installation is complete.

The tank is supplied with full installation instructions and is labelled with the IAB identification Mark incorporating the number of this Certificate.

The tank should be stored upright, on level ground, with the cover in place to prevent ingress of water.

2.4 INSTALLATION

2.4.1 General

Kilkenny Pre-Cast Concrete Ltd recommends that a competent person, e.g. an appropriately qualified and experienced engineer or surveyor, conduct a site suitability assessment. Based on this assessment, the competent person should design and supervise installation and commissioning of the unit.

It is Kilkenny Pre-Cast Concrete Ltd's policy to

- offer a site assessment and system design service;
- deliver, off load, and lift each unit into the excavation provided, using specially selected lifting equipment;
- supply detailed installation instructions;
- supervise the installation of the unit;
- commission all systems before use.

Installation (including electrical wiring of control panel and air blower) shall be carried out by competent persons in accordance with the installation instructions provided (see Cl 2.4.2).

2.4.2 Electrical Works

Electrical connections shall be strictly in accordance with the Certificate holder's instructions, ET101: 2002 *National Rules for Electrical Installations (3rd Edition) incorporating Amendment No. 1 2001 and ET 207: 2003 Guide to the National Rules for Electrical Installations As Applicable To Domestic & Similar Installations*, published by the Electro-Technical Council of Ireland (ETCI).

All electrical works, and connections to the mains supply board, shall be carried out by a competent person, using materials suitable for the purpose (e.g. a 2.5 mm² five core SWA cable complete with earth).

Electrical cables shall be protected from accidental damage e.g. by a suitable conduit. It is recommended that the control panel is clearly visible from a suitable location within the house.

2.4.3 Site Works

The excavation shall be of sufficient size to permit placement of the unit and back filling and to allow for timbering and sheeting as necessary to meet the requirements of The Safety, Health and Welfare at Work Act, 1989. There should be sufficient area on site to permit excavation, dumping of excess spoil, backfilling, handling and installation, without causing damage to the unit or the ancillary equipment.

It is essential to prevent damage due to superimposed loading, from vehicles or site traffic. A suitable fence shall be erected around the unit to restrict loading. The distance between the fence and the unit should be equal to or greater than the depth of excavation for the unit.

Care shall be taken to prevent accidental damage arising from blows from tools, or concentrated pressure on the shell from levering etc.

Similarly, sharp corners or edges of bricks and stones shall be kept clear of the unit. This shall be borne in mind when back filling, as the resultant load of a sharp object could fracture the unit.

The tank should not be lifted if it contains water.

2.4.4 Design

The potential suitability of a site, for the installation of such a system, shall be assessed using the methodology outlined in the EPA *Wastewater treatment manual – Treatment Systems for Single Houses 2000*. The ground water protection responses set out in 'Groundwater Protection Responses for on-site Wastewater Systems for Single Houses' published by EPA/DoELG/GSI (2001) should be used in the desk study assessment of the site, to give an early indication of the suitability of the site for such a system.

The system should only be installed where a competent authority determines the ground conditions, and the water table levels, to be adequate to support the tank, and to provide for disposal of the effluent in accordance with relevant regulations. The system should not be installed in unsuitable ground conditions.

Where poor ground conditions prevail, e.g. soft ground or shrinking clay, further advice must be sought from a competent person, to establish if the ground is adequate to support the tank and prevent differential settlement.

Good ground working practice shall be followed, particularly with regard to the gradient on drainage pipe runs. The inlet pipe should have a gradient of between 1:40 and 1:60. The outfall pipe should have a final gradient of between 1:70 and 1:200.

Storm water run-off e.g. from roofs or paved areas shall be excluded from the system. The system shall not be installed in areas liable to localised flooding, unless adequate additional protection is provided in accordance with the Certificate holder's instructions.

The thickness and strength of concrete surround shall be selected to suit the ground conditions, imposed loads etc, for the design life of the unit. Minimum requirements are given in this certificate.

Adequate provision should be made for access, inspection and maintenance, in the drainage system upstream and downstream of the unit, through the provision of manholes, distribution chambers etc.

Adequate provision shall be made for ventilation, to ensure that noxious odours and dangerous gases can escape.

2.4.5 Health and Safety

Excavation, placing and backfilling should be carried out strictly in accordance with the requirements of the Safety, Health and Welfare at Work Act 1989 and all other relevant legislative requirements.

2.4.6 Procedure

a) Equipment and materials

It is recommended that all plant and materials necessary for the installation should be on site before excavation commences.

b) Tank Installation – dry site

A dry site is defined as one where the local water table never rises above the base of the treatment unit.

The tanks shall be installed as follows:

1. A pit should be excavated to a depth to suit the invert level of the incoming drain. The Certificate holder recommends an excavation of minimum dimensions: 4 m long x 1.5 m wide x 1.8 m below incoming invert level.
2. Care shall be taken to eliminate voids and soft spots beneath the tank. All water, sharp stones and boulders shall be removed from the excavation. The unit may be bedded on firm excavated ground, or where necessary eg poor ground, on a firm level concrete base. The concrete shall be of sufficient grade (minimum 25N) and thickness (minimum 150 mm) to ensure that the unit is adequately supported with due regard to subsoil conditions and imposed loads.
3. The tank base is carefully lowered onto the excavation base, using purpose made lifting equipment, which is attached to projecting ribs at either end of the tank.
4. The inlet should be in line with the drain from the premises to be served. Care should be taken to prevent damage to external flanges or pipe work and to ensure correct orientation of the outlet pipe work. The base shall be level horizontally and truly vertical before the lid is sealed into place using SBR mortar.
5. The excavation is then backfilled using selected self-compacting pea gravel or suitable granular material, (compaction factor of 0.2 or less, all rocks and large stones removed). The backfill must be carefully consolidated to prevent local stress concentrations and uneven transfer of ground loads. The system should be ballasted when backfilling. The backfilling should be scheduled to permit connection of drainage pipework.

c) Additional requirements for wet sites

A wet site is defined as one where the local water table can rise above the base of the treatment unit.
Installation in a wet site may be precluded by site considerations in relation to effluent disposal.

6. A 250 mm hardcore sub-base is laid, compacted and levelled.
7. The excavation is kept dry by pumping excess water using a site pump/sump hole/suction hose arrangement. Dewatering should be continued for as long as necessary and at least until the concrete has set.

8. The excavation is then lined with a continuous layer of 1200 gauge polyethylene sheet. The installation should then continue in accordance with the requirements for dry sites. The grade and thickness of the concrete base should be designed to suit site conditions (minimum 250 thick, grade 25N).

d) Drainage Connections

The tank is provided, at the inlet and outlet, with 110mm uPVC pipes connections to BS 4660. These should be connected, via a flexible connection to allow for differential movement, (300mm length of pipe with flexible joints), to the drainage system. Suitable adapters shall be used for connection to other types of pipe work.

e) Ducting

A 100 mm uPVC duct should be laid from the marked connection point on the unit to the power supply.

f) Completion of backfilling

When connections to drainage pipe work are complete and ducting in place, continue backfilling, terminating approximately 200 mm below ground level. The remaining backfilling should be completed to ground level, using selected non-angular excavated material or topsoil.

Table 2: Minimum Separation Distance (m).

	Unit	Irrigation Area
Dwelling served	7 ¹	10 ³
Adjacent dwelling	7 ¹	10 ³
Wall	3.5 ¹	3
Road	4 ¹	4
Site boundary	3.5 ¹	3
Potable Water source	10	30-100 ²
Water course	10	10
Lake	50	50

2.5 LOCATION

The units should be sited so that adequate access is available for safe installation, subsequent maintenance and de-sludging of the unit. De-sludging should be carried out by means of a de-sludging tanker, which requires access to within 30m of the unit. The minimum separation distances given in Table 2 apply.

1. The depth of excavation to accommodate the unit shall be taken into account when determining this distance. The separation distance should be such that the excavation does not undermine adjacent buildings, roads or walls. This distance should be not less than 1.5 times the excavation depth.
2. The separation distance should be not less than 30 metres except in the case of very free draining soils or gravels, where a minimum distance of 40 metres should be maintained. The irrigation area should be down hill of any nearby well. Where this is not possible, a separation distance of at least 100 metres shall apply. For further details see *Ground Water Protection Responses for On-Site Waste Water Systems for Single Houses* published by EPA/DoELG/GSI (2001).

3. These minimum permissible distances are for guidance only. A 'Competent Person' should assess each site on its own merits. However, where the site permits, irrigation areas should be located at greater separation distances from the dwelling. Also where possible on sloping sites, the irrigation area should be down slope from the dwelling.

2.6 TREATED WASTE WATER DISPOSAL

2.6.1 General Principles

The unit produces a fully treated wastewater, (BOD <20 mg/l; suspended solids <30 mg/l), which is more easily absorbed into soil strata than septic tank effluent. There are two methods used for the disposal of treated wastewater i.e.:

- a) Sub-surface irrigation, or
- b) Raised percolation bed.

2.6.2 Site Suitability Assessment

A 'competent person', as defined by the appropriate Authority, should undertake the site suitability assessment, and choice of disposal method (see Cl 2.4.4).

The assessment shall include a detailed visual inspection of the site, inspection of the trial hole for soil profile, depth of water table, percolation value, (e.g. Standard 'T/P' test), together with local knowledge of the area. From this information it should be possible to ascertain the suitability of the site and the size and type of percolation area required.

The results of this assessment will (a) determine if the site is suitable and (b) enable the selection of the most suitable method for disposing of the final treated effluent, having due regard to soil type and percolation characteristics, water table level and other factors.

Guidance for sizing of a percolation area is set out in Table 3. Treated wastewater is discharged from the unit by gravity or by pumping if a raised bed facility is required (See Cl 2.1.1).

2.6.3 Sub-Surface percolation

The treated wastewater discharges, by pump or by gravity, into a network of perforated pipes laid in stone filled trenches. The objective is to spread the effluent as evenly as possible over the required land area, thus minimising the possibility of the ground becoming over-saturated.

The discharge from the unit contains minimal suspended solids and is therefore, much more readily absorbed than septic tank effluent. The extent of the irrigation system is determined by the site assessment, taking into account the soil type and percolation test results, as well as the population to be served (see Table 3). These values are given for guidance only and should be discussed in detail with the competent person who conducted the site suitability assessment.

Trenches are generally 450 mm wide. The base of the trench should be at 600 to 1200 mm above the water table or fissured bedrock (as per EPA guidelines). Typically, perforated pipe (110 mm OD for gravity discharge; 32 mm OD for pumped discharge) is laid on a 250 mm bed of clean 20/30 mm washed stone or gravel. The percolation trench is backfilled to give

500 mm overall depth of washed stone or gravel. The trench is then covered with a geotextile layer, before final backfilling to ground level with 300 mm topsoil.

Layout of the trenches will be determined by site topography; the overall fall of the pipes should be not more than 1 in 200.

2.6.4 Raised percolation bed

Where raised percolation beds are required e.g. thin topsoils and/or rock or water table close to the surface, the capacity of the pump needs to be selected to suit (See Cl 2.1.1).

The percolation trench construction is similar to that specified for sub-surface percolation. The base of the percolation trench should be at least 600 mm to 1200 mm above the highest water table or fissured bedrock (as per EPA guidelines). The perforated pipe is laid on a 250 mm bed of clean 20/30 washed stone or gravel. The trench is then backfilled to give an overall depth of 500mm. The trench is covered with a geotextile layer, before backfilling to ground level with 150 mm minimum of good quality topsoil.

2.6.5 Provision for inspection of percolation area

For monitoring, sampling and maintenance purposes, access to the effluent percolation systems should be provided at the end of each irrigation or filter trench via a suitably constructed inspection chamber.

2.6.6 Further treatment

In some instances (e.g. proximity to a drinking water source), the effluent may require "polishing" before discharge, to reduce coliform bacteria levels. A commonly used method is to pass the discharge through a sand filter. In this situation, the discharge is pumped to the sand filter using an effluent pump set capable of discharging in 180 litre doses. Polishing filters can be partly or wholly above ground soil, covered or open. A typical filter serving a 4-person household would have a plan area of 8 m² to 20 m², depending on design and type of sand used.

Where part of the polishing system is exposed above ground, care shall be taken to ensure there is no risk of casual or accidental access to the area.

2.7 ALARM

An audible and visual alarm is supplied to warn of power failure or high water level.

2.8 COMMISSIONING

Kilkenny Pre-Cast Concrete Ltd. shall carry out commissioning after installation is complete and all services are connected.

2.9 SERVICING AND MAINTENANCE

Kilkenny Pre-Cast Concrete Ltd. offers service and maintenance contracts and can also carry out repair work.

2.10 ENCLOSURE

The area around the tank and percolation area should be fenced off to protect it from farm animals and other unwanted traffic.

Table 3: Guidance for sizing of percolation area (linear metres of percolation pipe)

Population served	T/P values 21-50* Loading at 25l/ m ² per day	T/P values 1-20* Loading at 50l/ m ² per day
3	48	24
4	64	32
5	80	40
6	96	48
7	112	56
8	128	64

* based on 450 mm trench width

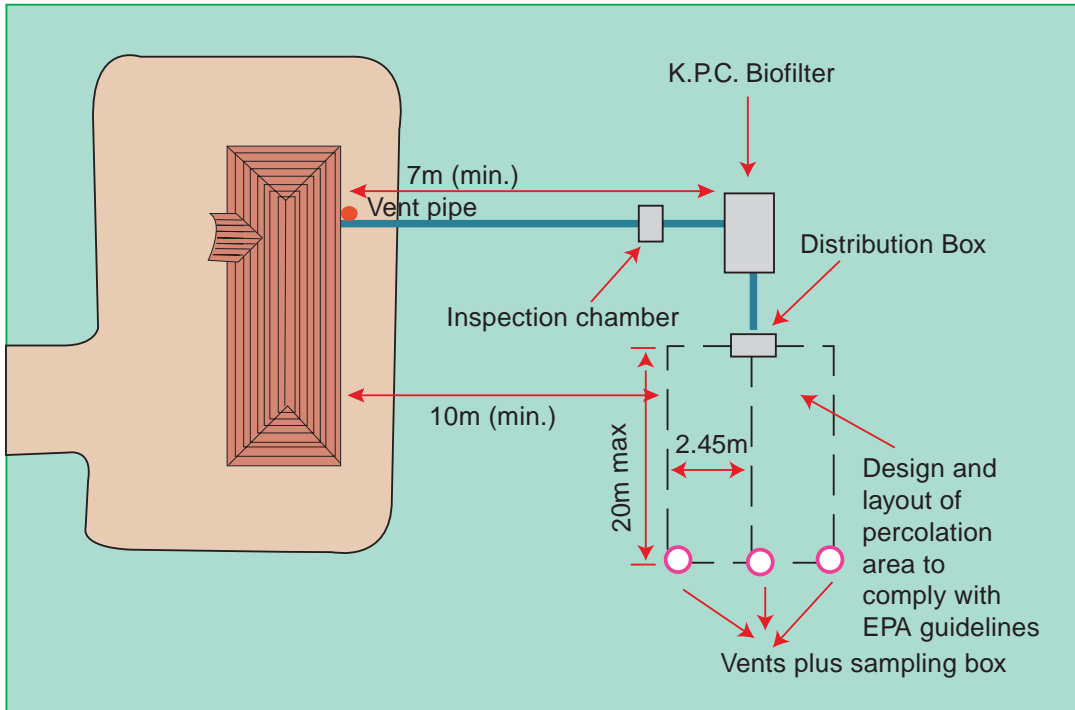

Note: all separation distances to comply with EPA Guidelines

Figure 2: Schematic layout for wastewater treatment system

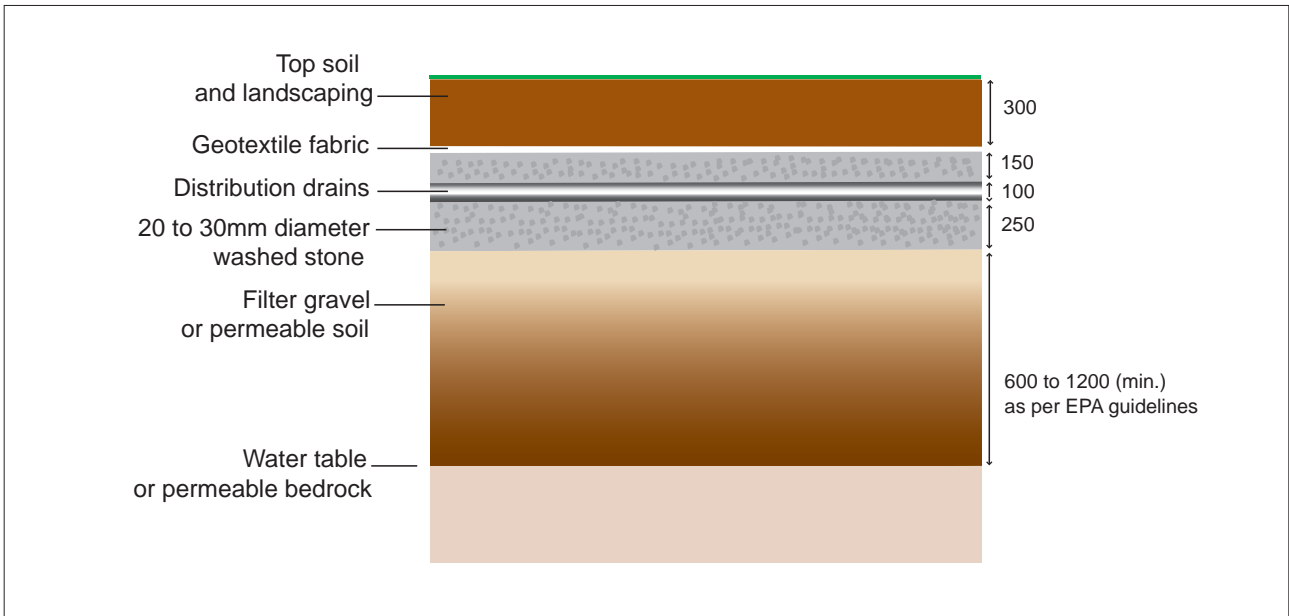

Figure 3: Percolation trench

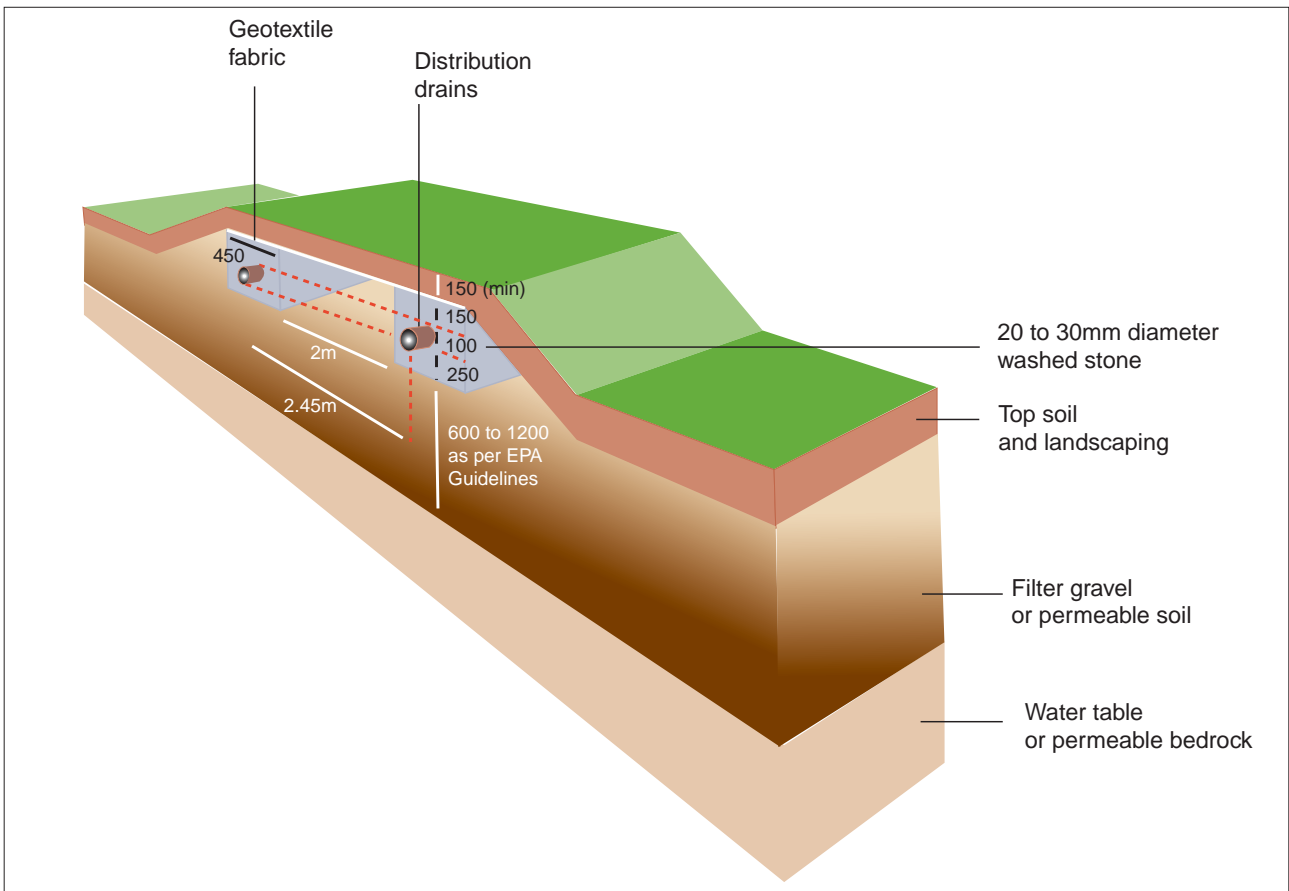

Figure 4: Raised percolation trench

3.1 GENERAL

The KPC Biofilter Wastewater Treatment System is suitable for the collection and treatment of domestic wastewater and shall be installed in accordance with the Certificate holder’s instructions, the EPA *Wastewater treatment manual – Treatment Systems for Single Houses 2000* and to conform with the recommendations of BS 6297: 1983. The following conditions shall apply:

- Design loadings shall be based on the maximum population served;
- The Certificate holder or his agent for inspection/audit maintains detailed site assessment records and installation locations.
- The unit shall be sited/installed in accordance with the relevant Building Regulations.
- Ground water and flood levels shall always be below outlet level.
- The effluent shall be discharged to a suitable sub-soil irrigation system or raised percolation bed. The irrigation system shall be correctly designed in accordance with the detailed site assessment report for the ‘particular site’.
- All wastewater treatment systems shall be indelibly marked with the model type and population equivalent in such a way that when installation has been completed, these details are clearly visible for record purposes.

The effluent from the unit will normally be within Royal Commission Standard (i.e. suspended solids content less than 30 mg per litre and Biochemical Oxygen Demand (BOD) less than 20 mg per litre) provided that the hydraulic and BOD loadings are within the limits recommended by the Certificate holder for the unit installed (180 litres per head per day and 60 grammes per head per day, respectively). Under certain unusual conditions, the resulting effluent may not be within Royal Commission Standards. This is normal for any biological sewage treatment process, and may be caused by unusual hydraulic or BOD loading, weather conditions, contamination by excessive quantities of (a) offal and grease, (b) household disinfectants, (c) detergents or poisoning of microbiological flora or fauna by other chemicals.

3.2 DESIGN BASIS

3.2.1 General

The relevant dimensions of KPC Biofilter Wastewater Treatment System certified in this Agrément Certificate are shown in Table 1.

3.2.2 Wastewater quality

Table 4: *Treated wastewater characteristics*

pH	6-9
BOD	< 20mg/l O ₂
Suspended Solids	< 30mg/l

The specification and power requirements of the KPC Biofilter Wastewater Treatment System are listed in Table 1.

A short period of acclimatisation shall be allowed after commissioning of the unit before a full degree of treatment can be expected. This period is generally a few weeks and is normal for any biological treatment plant.

4.1 ENVIRONMENTAL ASSESSMENT

The treated wastewater from a number of working units has been monitored. The test results show that values stated for the parameters listed in Table 4 are consistently achievable over a range of operating conditions.

4.2 STRENGTH

The Certificate holder's design has been assessed as satisfactory. The unit has adequate resistance to resist damage from minor impacts during handling but it shall be slung in accordance with the Certificate holder's instructions.

The unit has sufficient structural strength to resist soil loads in non-cohesive dry soils, but it is recommended that excavations are backfilled in accordance with 2.4.6.b) and c), to resist uplift of units, due to buoyancy. The cover and frame assembly is suitable for pedestrian traffic only.

4.3 WATERTIGHTNESS

The system, when correctly installed, has been assessed as fully capable of preventing seepage either into or from the surrounding soil. The pipe joints, when correctly made, will be watertight.

4.4 DURABILITY

In the opinion of the IAB the product will have a life in excess of 50 years when installed in accordance with this Certificate in normal soil conditions. The mechanical and electrical components may require replacement within the design life.

4.5 MAINTENANCE

Cleaning and maintenance should be carried out in accordance with the Certificate holder's Operation and Maintenance Instructions.

Access to the tank interior is via the manhole covers provided, using specially designed lifting keys.

Kilkenny Pre-Cast Concrete Ltd strongly recommends that access to the tank interior be restricted to, and all maintenance work be carried out by Kilkenny Pre-Cast Concrete Ltd trained operatives or authorised and competent maintenance contractors.

The compressor can be readily accessed for cleaning and maintenance. The media and the associated pipe work can be accessed for removal/cleaning by removing the concrete lid. The lid must be resealed on replacement.

The tank is easily de-sludged, in the conventional manner by a suction tanker. De-sludging should be

carried out in accordance with the Certificate holder's instructions.

Summary of maintenance instructions

The KPC Biofilter Wastewater Treatment System is de-sludged by a suction tanker. Care shall be taken to avoid damage by the hose nozzle. The primary chamber shall be de-sludged, through the sludge removal access, in accordance with the Certificate holder's recommendations.

Frequency of inspection

It is recommended that the homeowner should conduct an inspection of the system regularly, and at least every six months, in accordance with the Certificate holder's 'Operation and Maintenance instructions'.

4.6 SAFETY

4.6.1 Safety of personnel

The access covers can be securely fixed. They are not lockable, but are considered to be sufficiently heavy to prevent easy removal by children and unauthorised access. The access covers shall not be left off an unattended tank.

Sewage treatment plants are potentially dangerous, particularly when being de-sludged. De-sludging shall never be carried out alone. If it is necessary to enter the unit, adequate safety precautions shall be made to ensure the safety of personnel involved. Naked lights, which can cause explosions, shall not be used in the vicinity of the tanks.

The unit should be positioned, or marked, or protected, to prevent superimposed loading or accidental impact by vehicles.

4.7 TESTS AND ASSESSMENTS WERE CARRIED OUT TO DETERMINE THE FOLLOWING:

- Watertightness.
- Strength of cover and frame assemblies.
- Resistance of units to hydrostatic and ground pressure.
- Resistance to lifting forces
- Resistance to flotation.
- Environmental performance.
- Concrete cube strength

4.8 OTHER INVESTIGATIONS

- (i) The manufacturing process was examined including the methods adopted for quality control, and details were obtained of the quality and composition of the materials used.
- (ii) An examination of the results of sample analysis of effluent from the system, to measure suspended solids content and Biochemical Oxygen Demand, was undertaken.
- (iii) An assessment of the tank was made in relation to degradation of mechanical properties owing to exposure to sewage, ground water, dissolved salts and dilute acids or alkalis; long-term loading conditions.
- (iv) Site visits were conducted to assess the practicability of installation
- (v) Bought in components were assessed for suitability for use.

No failures of the product in use have been reported to the IAB.

- 5.1** National Standards Authority of Ireland ("NSAI") following consultation with the Irish Agrément Board ("IAB") has assessed the performance and method of installation of the product/process and the quality of the materials used in its manufacture and certifies the product/process to be fit for the use for which it is certified provided that it is manufactured, installed, used and maintained in accordance with the descriptions and specifications set out in this Certificate and in accordance with the manufacturer's instructions and usual trade practice. This Certificate shall remain valid for five years so long as:
- (a) the specification of the product is unchanged.
 - (b) the Building Regulations 1997 to 2002 and any other regulation or standard applicable to the product/process, its use or installation remains unchanged.
 - (c) the product continues to be assessed for the quality of its manufacture and marking by NSAI.
 - (d) no new information becomes available which in the opinion of the NSAI, would preclude the granting of the Certificate.
 - (e) the product or process continues to be manufactured, installed, used and maintained in accordance with the description, specifications and safety recommendations set out in this certificate.
 - (f) the registration and/or surveillance fees due to IAB are paid.
- 5.2** The IAB mark and certification number may only be used on or in relation to product/processes in respect of which a valid Certificate exists. If the Certificate becomes invalid the Certificate holder must not use the IAB mark and certification number and must remove them from the products already marked.
- 5.3** In granting Certification, the NSAI makes no representation as to;
- (a) the absence or presence of patent rights subsisting in the product/process; or
 - (b) the legal right of the Certificate holder to market, install or maintain the product/process; or
 - (c) whether individual products have been manufactured or installed by the Certificate holder in accordance with the descriptions and specifications set out in this Certificate.
- 5.4** This Certificate does not comprise installation instructions and does not replace the manufacturer's directions or any professional or trade advice relating to use and installation which may be appropriate.
- 5.5** Any recommendations contained in this Certificate relating to the safe use of the certified product/process are preconditions to the validity of the Certificate. However the NSAI does not certify that the manufacture or installation of the certified product or process in accordance with the descriptions and specifications set out in this Certificate will satisfy the requirements of the Safety, Health and Welfare at Work Act, 1989, or of any other current or future common law duty of care owed by the manufacturer or by the Certificate holder.
- 5.6** The NSAI is not responsible to any person or body for loss or damage including personal injury arising as a direct or indirect result of the use of this product or process.
- 5.7** Where reference is made in this Certificate to any Act of the Oireachtas, Regulation made thereunder, Statutory Instrument, Code of Practice, National Standards, Manufacturer's instructions, or similar publication, it shall be construed as reference to such publication in the form in which it is in force at the date of this Certification.

The Irish Agrément Board

This Certificate No. **05/0216** is accordingly granted by the NSAI to **Kilkenny Pre-Cast Concrete Ltd** on behalf of The Irish Agrément Board.

Date of Issue: **March 2005**

Signed



Chief Executive, NSAI

Readers may check that the status of this Certificate has not changed by contacting the Irish Agrément Board, NSAI, Glasnevin, Dublin 9, Ireland. Telephone: (01) 807 3800. Fax: (01) 807 3842. www.nσαι.ie